



# 光电耦合器

## OPTOCOUPLER

产品规格书  
Product Data Sheet

# Si-M501 系列

## Si-M501 Series

Si DCC  
Release

贵州硅耐光电有限公司

GuiZhou Silicon Nice Optoelectronic Co., Ltd.

## 描述 Description

Si-M501 系列将一个 AlGaAs 红外发光二极管作为发射器，该发射器通过 SOP5 封装与硅高速光电晶体管进行光学耦合。凭借坚固的共面双模结构，Si-M501 系列提供了最稳定的隔离特性。

The Si-M501 series combine an AlGaAs infrared emitting diode as the emitter which is optically coupled to a silicon high speed photo transistor in a plastic SOP5 package. With the robust coplanar double mold structure, Si-M501 series provide the most stable isolation feature

## 典型应用 Typical Applications

- 通信设备  
Telecommunication equipment
- CMOS-LSTTL-TTL 的输出接口  
Out interface to CMOS-LSTTL-TTL
- 计算机外围设备接口  
Computer-peripheral interface
- 电机驱动中的功率晶体管隔离  
Power transistor isolation in motor drives

## 特性 Features

- 高比特率：1MBit/s  
High Speed-1MBit/s
- 高隔离电压( $V_{ios}=3750V_{RMS}$ )  
High isolation( $V_{iso}=3750V_{RMS}$ )
- 集电极开路输出  
Open-Collector Output
- 宽工作温度：-40~100℃  
Wide operating temperature range: -40℃ to 100℃

真值表 Truth Table	
发光二极管 LED	$V_{CC}-V_{EE}$ POSITIVE GOING
OFF	HIGH
ON	LOW

## 封装与功能图 Package and Functional Diagram

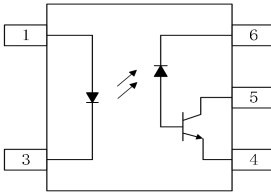
封装 Package	内部连接图 Internal Connection Diagram	引脚分配 Pin Assignment
 SOP5		1: Anode                      5: VCC 4: $V_o$ 2: Cathode                    3: GND



## 安规与绝缘参数 Safety and Insulation Ratings

参数 Parameter		符号 Symbol	数值 Value	单位 Unit
最大额定隔离电压 Maximum Rated Withstanding Isolation Voltage	According to UL1577, t = 1 min	$V_{ISO}$	3700	$V_{RMS}$
最大瞬态隔离电压 Maximum Transient Isolation Voltage	According to DIN EN 60747-5-5	$V_{IOTM}$	5000	$V_{peak}$
最大峰值重复隔离电压 Maximum Repetitive Peak Isolation Voltage	According to DIN EN 60747-5-5	$V_{IORM}$	600	$V_{peak}$
爬电距离 Creepage Distance	/	L	5	mm

## 极限参数 Absolute Maximum Ratings

参数 Parameter		符号 Symbol	最小值 Min.	极限值 Rating	单位 Unit
输入端 Input	平均输入电流 Average Input Current	$I_{F(AVG)}$	-	25	mA
	反向电压 Reverse Voltage	$V_R$	-	5	V
	功耗 Power Dissipation	P	-	45	mW
	瞬态峰值输入电流(<1 $\mu$ s pulse width, 300 pps) Peak Transient Input Current (<1 $\mu$ s pulse width, 300 pps)	$I_{F(TRAN)}$	-	1	A
	结温 Junction Temperature	$T_J$	-	125	$^{\circ}C$
输出端 Output	电源电压 Supply Voltage	$V_{CC}$	-0.5	30	V
	输出电压 Output Voltage	$V_O$	-0.5	20	V
	输出电流 Output Current	$I_O$	-	8	mA
	峰值输出电流 Peak output current	$I_{O(PEAK)}$	-	16	mA
	输出功率 Output power dissipation	$P_O$	-	100	mW
	结温 Junction Temperature	$T_J$	-	125	$^{\circ}C$
工作温度 Operating Temperature	$T_{amb}$	-40	+100	$^{\circ}C$	
存储温度 Storage Temperature	$T_{stg}$	-55	+125	$^{\circ}C$	
焊接温度 Soldering Temperature	$T_{sld}$	-	260	$^{\circ}C$	



产品特性参数 Electro-optical Characteristics ( $T_{amb}=25^{\circ}C$ )

参数 Parameter		测试条件 Test Conditions	符号 Symbol	最小值 Min.	典型值 Typ.	最大值 Max.	单位 Units
输入端 Input	输入端正向电压 Input Forward Voltage	$I_F=16mA$	$V_F$	-	1.45	1.8	V
	反向电 Input Reverse Breakdown Voltage	$V_R=5V$	$I_R$	-	-	10	$\mu A$
	输入端电容 Input capacitance	$V_F=0, f=1MHz$	$C_{IN}$	-	60	-	pF
输出端 Output	高电平电源电流 High Level Supply Current	$I_F=0mA, V_O = Open,$ $V_{CC}=15V, T_A=25^{\circ}C$	$I_{CCH}$	-	-	1	$\mu A$
		$T_A=0-70^{\circ}C$		-	-	2	
	高电平电源电流 Low Level Supply Current	$I_F=16mA, V_O = Open,$ $V_{CC}=15V$	$I_{CCL}$	-	200	-	$\mu A$
	低电平输出电压 Low Level Output Voltage	$I_F=0mA,$ $I_O=100mA$	$V_{OL}$	-	0.1	0.3	V
	高电平输出电流 High Level Output Current	$I_F=0mA$ $V_O=V_{CC}=5.5V$	$I_{OH}$	-	0.001	0.5	$\mu A$
		$I_F=0mA$ $V_O=V_{CC}=15V$		-	0.01	1	
$T_A=0-70^{\circ}C$		-		-	50		
传输特性 Transfer Characteristics	电流传输比 Current Transfer Ratio	$I_F=16mA, V_{CC}=4.5V$ $V_O=0.4V$	CTR	20	-	-	%
		$I_F=16mA, V_{CC}=4.5V$ $V_O=0.5V$		15	-	-	
	低电平输出电压 Low Level Output Voltage	$I_F=16mA, V_{CC}=4.5V$ $I_O=3.0mA$	$V_{OL}$	-	-	0.4	V
		$I_F=16mA, V_{CC}=4.5V$ $I_O=2.4mA$		-	-	0.5	
	输出高电平传输延迟 Propagation Delay Time to High Output Level	$I_F=16mA$ $V_{CC}=5V$	$t_{PHL}$	-	-	800	ns
	输出低电平传输延迟 Propagation Delay Time to Low Output Level	$R_L=1.9k\Omega$ $T_A=25^{\circ}C$	$t_{PLH}$	-	-	800	ns
	逻辑高电平共模瞬态抗扰度 Common Mode Transient Immunity (at Logic High)	$I_F = 0mA, V_{CC}=5V$ $R_L=1.9k\Omega, T_A=25^{\circ}C,$ $V_{CM}=1000V$	$ CM_H $	15	-	-	kv/ $\mu s$
	逻辑低电平共模瞬态抗扰度 Common Mode Transient Immunity (at Logic Low)	$I_F = 16mA, V_{CC} = 5V,$ $T_A=25^{\circ}C, V_{CM}=1000V$	$ CM_L $	15	-	-	kv/ $\mu s$
隔离电阻 Isolation Resistance	$V_{I-O}=500V$	$R_{ISO}$	$10^{12}$	-	-	$\Omega$	
隔离电容 Isolation capacitance	$f=1MHz$	$C_{ISO}$	-	0.3	-	pF	

## 典型特性曲线 Typical Characteristics Curves

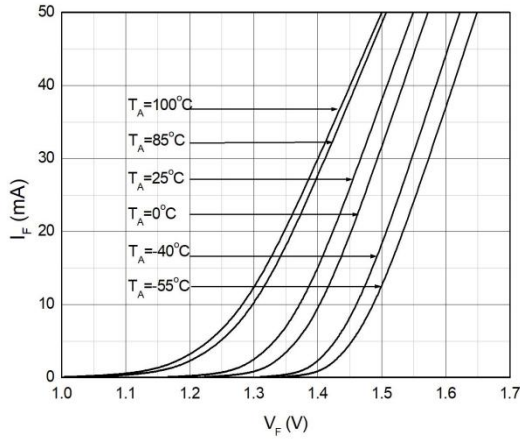

图例 1-正向电流与正向电压曲线图  
 Fig.1 Forward Current vs. Forward Voltage

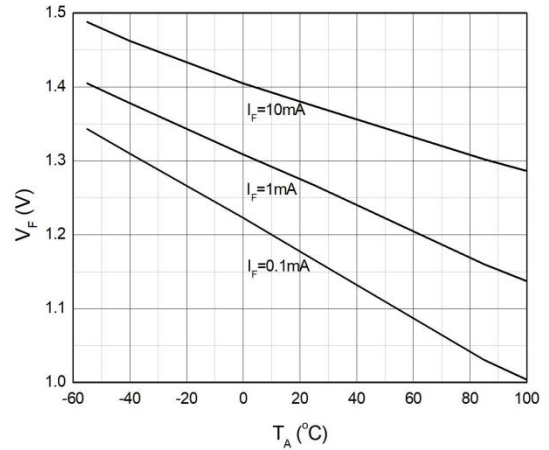

图例 2-正向电压与温度曲线图  
 Fig. 2 Forward Voltage vs. Temperature

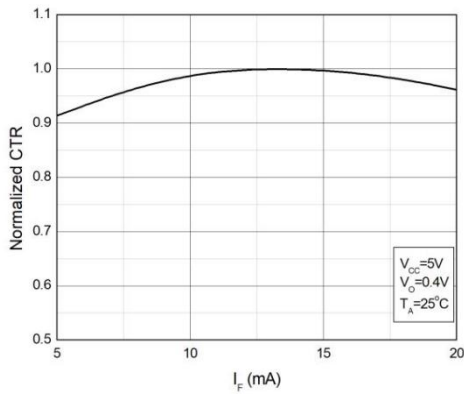

图例 3-归一化电流传输比与正向电流曲线图  
 Fig. 3 Normalized CTR vs. Input current

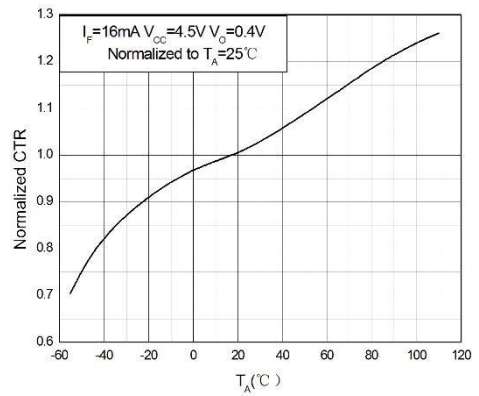

图例 4-归一化电流传输比与温度曲线图  
 Fig. 4 Normalized CTR vs. Temperature

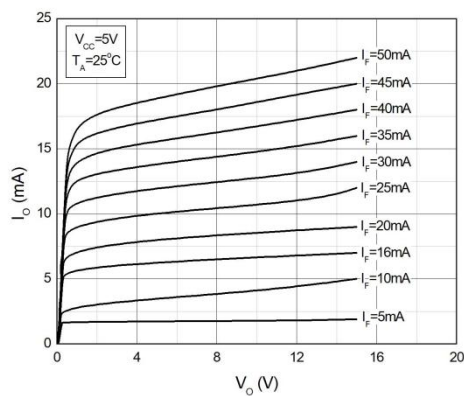

图例 5-输出电流与输出电压曲线图  
 Fig.5 Output Current vs. Output Voltage

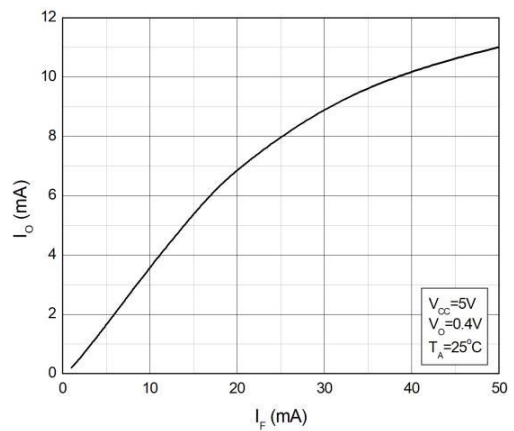

图例 6-输出电流与温度曲线图  
 Fig.6 Output Current vs. Forward Current

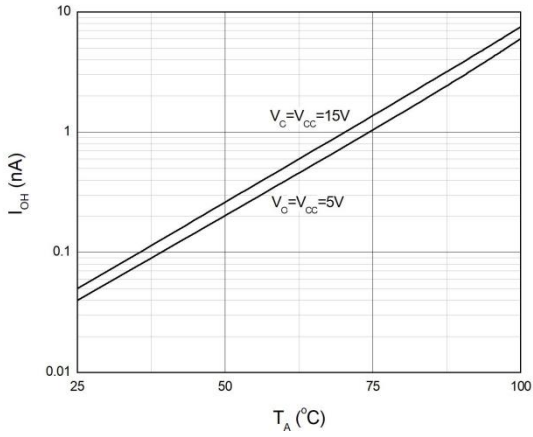

图例 7-高电平输出电流与温度曲线图

Fig.7 High Output Current VS. Temperature

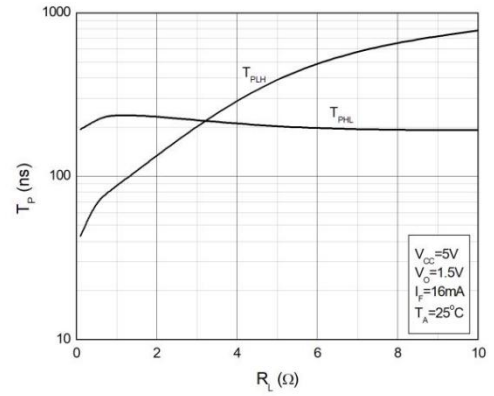

图例 8-传输延时与负载电阻曲线图

Fig.8 Propagation Delays vs. Load Resistance

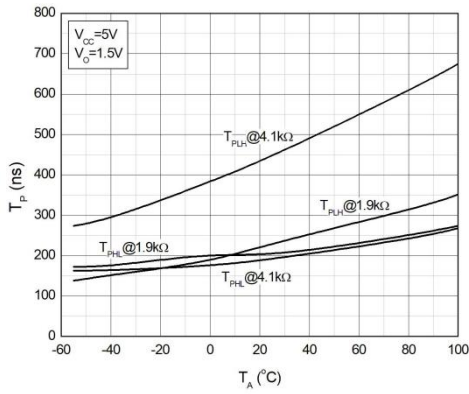

图例 9-传输延时与工作温度曲线图

Fig.9 Propagation Delays vs. Temperature

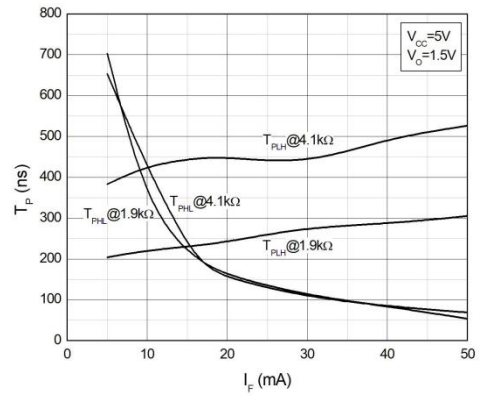

图例 10-传输延时与正向电流曲线图

Fig.10 Propagation Delays vs. Forward Current

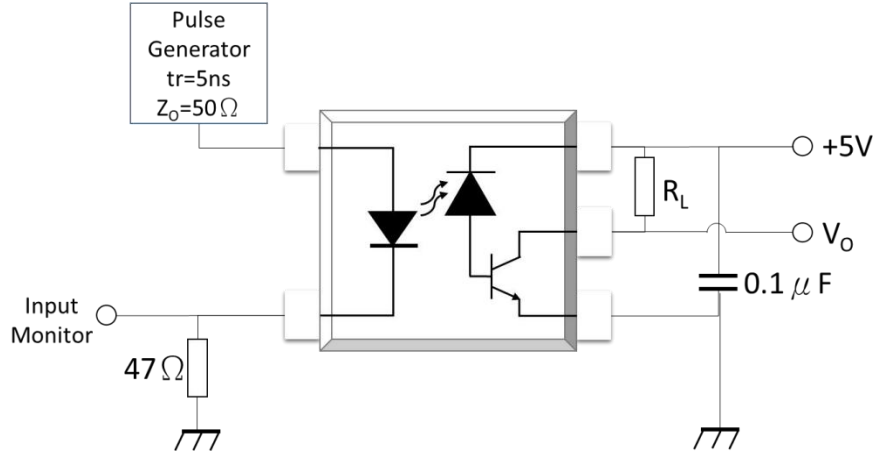

图例 11- $T_{PHL}, T_{PLH}$  测试电路

Fig.11  $T_{PHL}, T_{PLH}$  Test Circuit

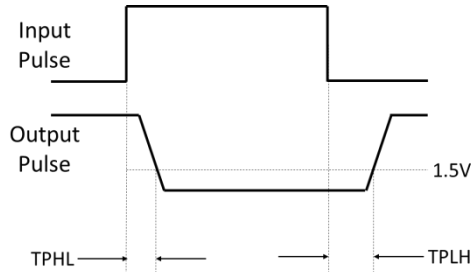

图例 12- $T_{PHL}, T_{PLH}$  波形

Fig.12 Waveforms of  $T_{PHL}, T_{PLH}$

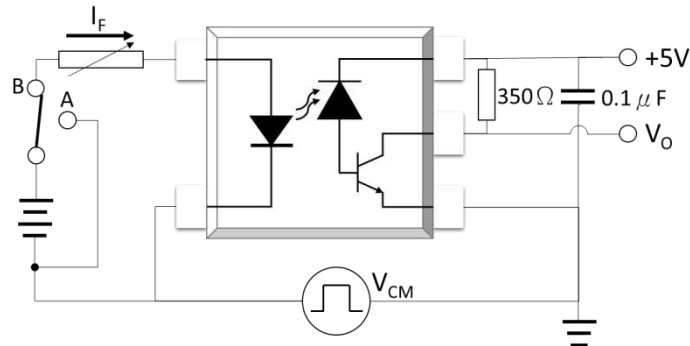

图例 13-CMR 测试电路

Fig.16 Test Circuits for Common Mode Transient Immunity

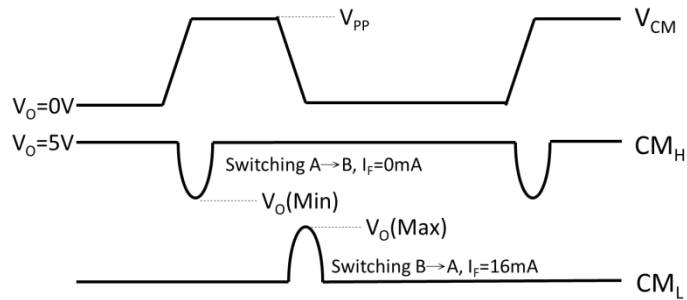

图例 14-CMR 波形

Fig.17 Wave forms of Common Mode Transient Immunity



## 印字信息 Marking Information



- ◆ Si: 生产商代码 Manufacturer's Code Marking
- ◆ M501: 器件型号代码 Device Part Number
- ◆ Y: 年份代码 Last Digit of Year (ex: 4=2024,5=2025)
- ◆ WW: 周号代码 Week Code (01 to 53)
- ◆ N: 特殊代码或无 Special code Or None

## 命名规则 Naming Rule

# Si-M501-WY-ZTT

- ◆ Si: 生产商代码 Manufacturer's Code Marking
- ◆ M501: 器件型号代码 Device Part Number
- ◆ W: 框架材质 (C=铜)
- ◆ Y: G/None (G=环保, None=非环保)
- ◆ Z: 封装 (Z=S:SOP5)
- ◆ TT: 补充码 A~Z or 0~9 or None

## 封装外形尺寸 Package Outline Dimensions

Si-M501

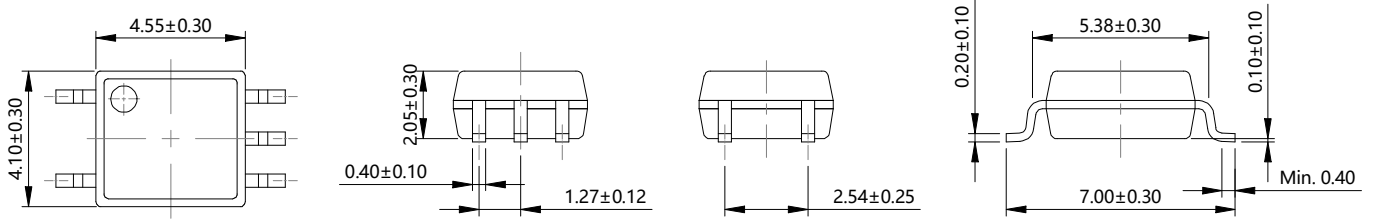

单位 Unit: mm

## 推荐焊盘尺寸 Recommended Footprint Patterns

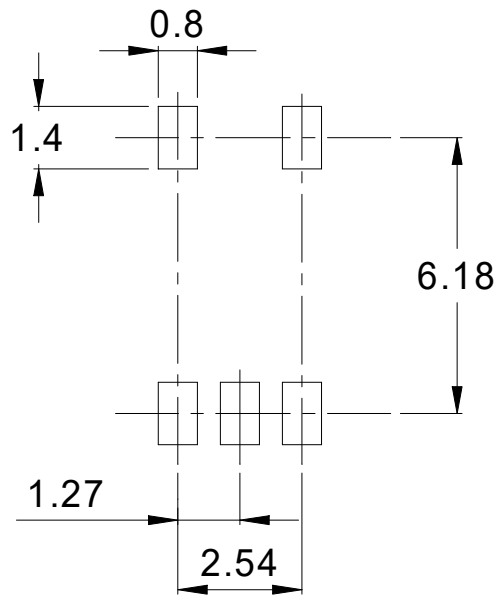

单位 Unit: mm

## 包装 Packing

封装类型 Package Type	每盘数量 Quantity per Reel	内盒数量 Quantity per Inner Box	外箱数量 Quantity per Carton	内盒尺寸 Inner Box Dimensions	外箱尺寸 Carton Dimensions
SOP5	3000 pcs/reel	6000 pcs/inner box	60,000 pcs/carton	353*340*60mm	650*375*365mm

## 载带与卷盘 Tape and Reel

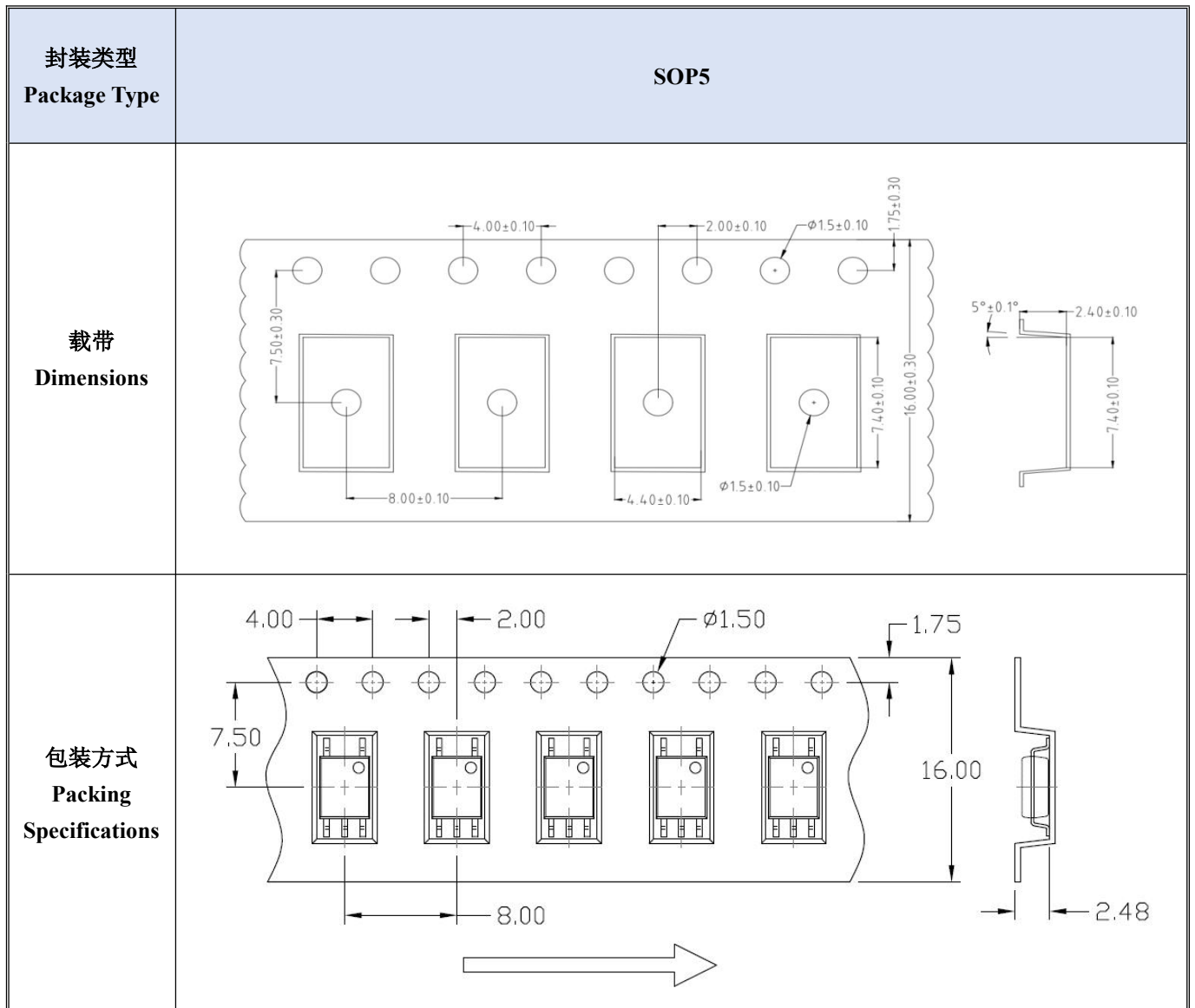

单位: mm

## 回流焊温度曲线 Solder Reflow Temperature Profile

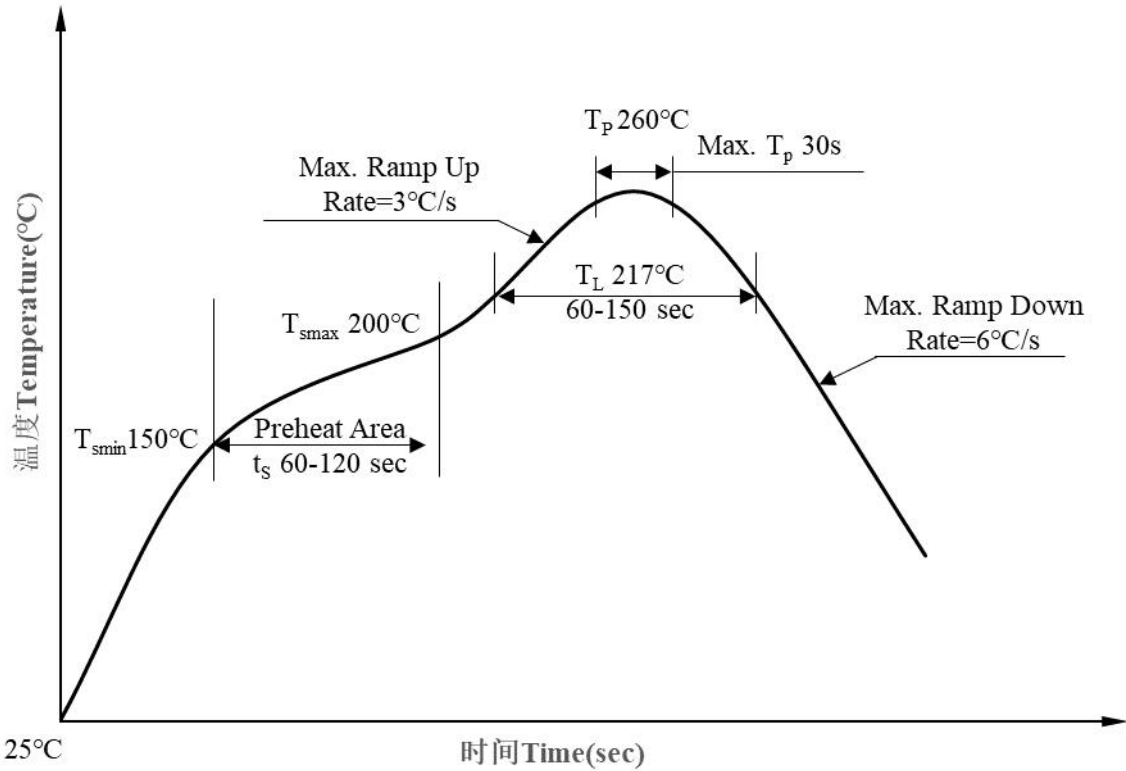

曲线项目 Profile Item		符号 Symbol	数值 Value	单位 Unit
预热区 Preheat Area	最低温度 Temperature Min.	$T_{smin}$	150	°C
	最高温度 Temperature Max.	$T_{smax}$	200	°C
	时间 Time (min. to max.)	$t_s$	60~120	sec
焊接区 Soldering Area	温度 Temperature	$T_L$	217	°C
	时间 Time	$t_L$	60~150	sec
峰值温度 Peak Temperature		$T_p$	260	°C
峰值温度 $T_p$ 至 $T_p-5^\circ\text{C}$ 之间的时间 Time within $5^\circ\text{C}$ of Peak Temperature: $T_p - 5^\circ\text{C}$		$t_p$	30	sec max.
上升速率 Ramp-up rate			3	°C / sec max.
下降速率 Ramp-down rate			6	°C / sec max.

注：参考 IPC/JEDEC J-STD-020D 标准。

Note: Reference: IPC/JEDEC J-STD-020D.

建议在所示的温度和时间条件下进行回流焊，最多不能超过三次。

One time soldering reflow is recommended within the condition of temperature and time profile shown below. Do not solder more than three times.

## 波峰焊温度曲线 Wave soldering Temperature Profile

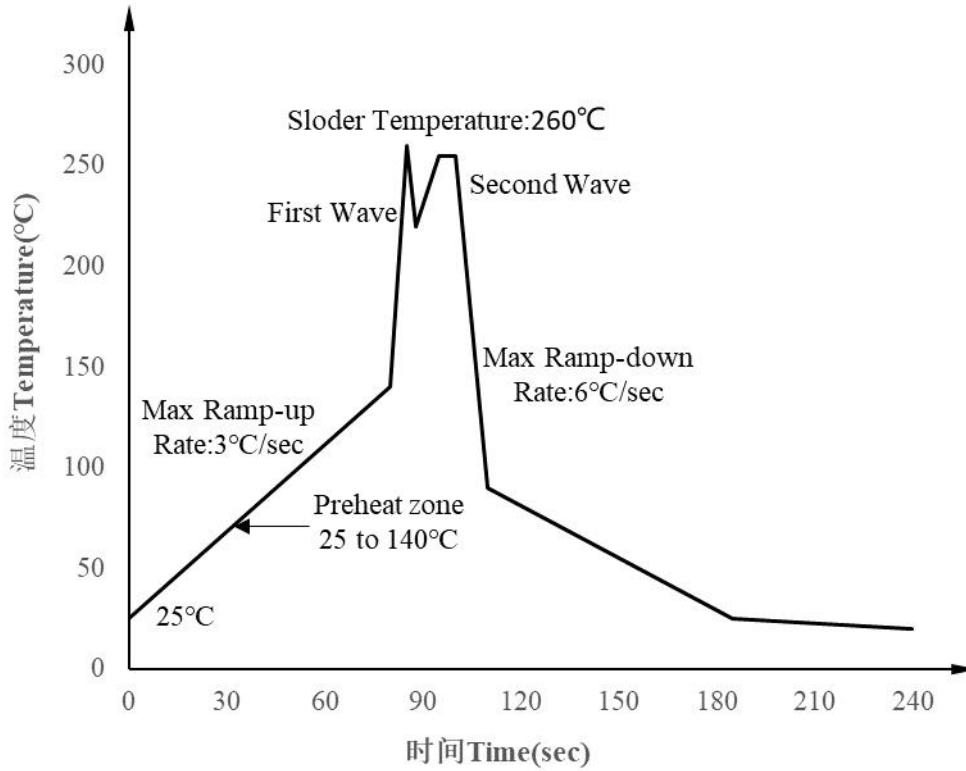

详情请参考 JEDEC 标准 JESD22-A111

For more details, please refer to the JESD22-A111 of JEDEC standards.

## 手工烙铁焊接 Hand soldering by soldering iron

- (1) 建议一次完成焊接。  
One time soldering is recommended.
- (2) 温度  $360^{\circ}\text{C} \pm 5^{\circ}\text{C}$ , 时间  $\leq 3\text{s}$ 。  
Temperature:  $360^{\circ}\text{C} \pm 5^{\circ}\text{C}$ , within 3s.

## 声明 Disclaimer

1. 为提高产品可靠性、功能或设计或其他方面，硅耐所有产品规格可能会进行更改，恕不另行通知。  
Silicon nice all product specifications are subject to change without notice to improve reliability, function or design or otherwise.
2. 使用本产品时请遵守规格书中的说明，硅耐对使用不符合这些规格表中说明的产品造成的损坏不承担任何责任。  
When using this product, please observe the instructions in this specifications. Silicon nice assumes no responsibility for any damage resulting from use of the product which does not comply with the instructions included in this specification sheets.
3. 本规格书所展示的产品为电子应用中的一般用途而设计，如办公自动化设备、通信设备、音频/视频设备、电气应用和仪器仪表等。  
The products shown in this specifications are designed for the general use in electronic applications such as office automation equipment, communications devices, audio/visual equipment, electrical application and instrumentation,etc.
4. 对于需要高可靠性或安全性的设备/装置，如太空应用、核电控制设备、医疗设备、任何“特定”应用等，请联系我们的销售代表。  
For equipment/devices where high reliability or safety is required, such as space applications, nuclear power control equipment, medical equipment, any "specific" application,etc, please contact our sales representatives.
5. 如对文件中表述的内容有疑问，欢迎联系我们。  
If you have any questions about the contents of the document, please contact us.